

Ground Fault Interrupter Earth Leakage Current Detector

IL7101

DESCRIPTION

The IL7101 is designed for use in earth leakage circuit interrupters for operation directly off the AC Line in breakers.

It contains pre regulator, main regulator, after regulator, differential amplifier, level comparator, latch circuit. The input in the differential amp latch circuit. The input in the differential amplifier is connecting to the secondary node of zero current transformer.

The level comparator generates high level when earth leakage current is greater than some level.

FEATURE

- Low Power Consumption ($P_D=5mW$) 100V/200V
- 100V/200V Common Built-in Voltage Regulator
- High Gain Differential Amplifier
- High Input Sensitivity
- Minimum External Parts
- Large Surge Margin
- Wide Operating Temperature Range ($T_A = -30$ to $85^\circ C$)
- High Noise Immunity
- Meet U. L. 943 standards

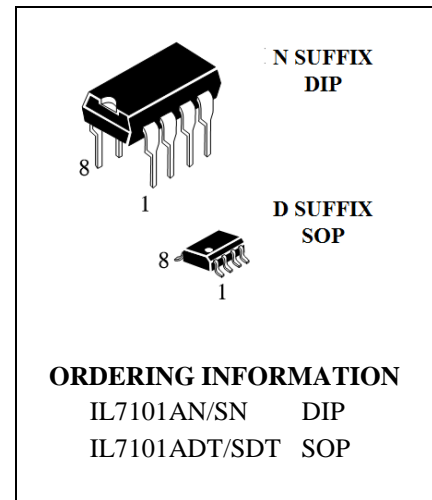

ORDERING INFORMATION

| Device | Trip Voltage | Operating Temperature Range | Package | Shipping |
|-----------|-----------------|---|---------|------------|
| IL7101SN | 8.55 to 10.1 mV | $T_A = -30^\circ$ to $85^\circ C$ for all packages | DIP-8 | Tube |
| IL7101AN | 9.9 to 10.65mV | | | |
| IL7101SDT | 8.55 to 10.1 mV | | SOP-8 | Tape& Reel |
| IL7101ADT | 9.9 to 10.65mV | | | |

ABSOLUTE MAXIMUM RATINGS

- Supply Voltage 20V
- Supply Current 8mA
- Power Dissipation 200mW
- Operating Temperature - 30 to $85^\circ C$
- Storage Temperature - 55 to $125^\circ C$

* Stresses beyond those listed under "absolute maximum ratings" may cause permanent damage to the device. These are stress ratings only and functional operation of the device at these or any other conditions beyond those indicated under "recommended operating conditions" is not implied. Exposure to absolute-maximum-rated conditions for extended periods may affect device reliability.

Pin Configuration

(Top View)

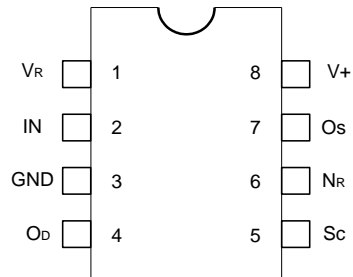

Block Diagram

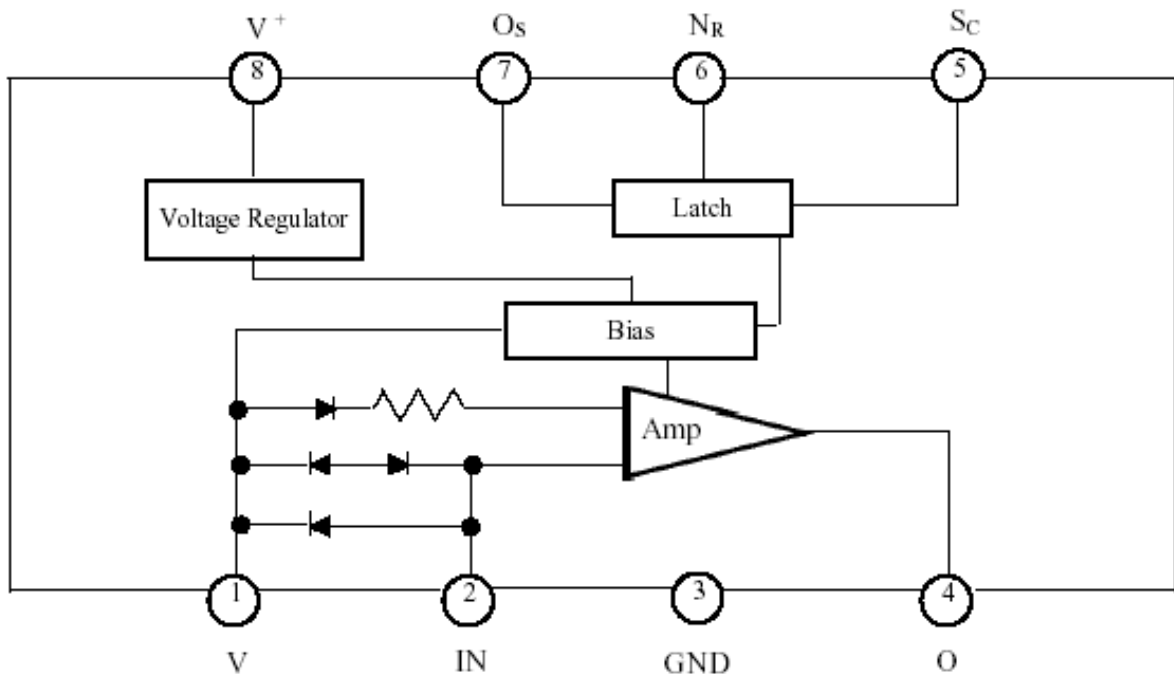

Recommended Operating Condition: $T_A = -30^{\circ}\text{C}$ to 80°C

| PARAMETER | SYMBOL | MIN. | TYP. | MAX | UNIT |
|-------------------------------|----------|------|------|-----|---------------|
| Supply Voltage | V^+ | 12 | | | V |
| Vs-GND Capacitor | C_{vs} | 1 | | | μF |
| O _S -GND Capacitor | C_{os} | | | 1 | μF |

Electrical Characteristics

| PARAMETER | SYMBOL | CONDCTIONS | TEMP ($^{\circ}\text{C}$) | MIN. | TYP. | MAX. | UNIT | |
|---|-------------------|---|--------------------------------|------|------|------|---------------|-------------|
| Supply Current 1 | I_{S1} | $V^+ = 12\text{V}$, $V_R - V_I = 30\text{ mV}$ | -30 | - | - | 580 | μA | |
| | | | 25 | - | 400 | 530 | | |
| | | | 85 | - | - | 480 | | |
| Trip Voltage | V_T | $V^+ = 16\text{V}$, $V_R - V_I = X$ | IL7101S | 25 | 8.55 | - | 10.1 | mV (rms) |
| | | | IL7101A | 25 | 9.9 | - | 10.65 | |
| Differential Amplifier Output Current 1 | I_{TD1} | $V^+ = 16\text{V}$, $V_R - V_I = 30\text{ mV}$ $V_{OD} = 1.2\text{ V}$ | 25 | -12 | - | -30 | μA | |
| Differential Amplifier Output current 2 | I_{TD2} | $V^+ = 16\text{V}$, $V_R - V_I = \text{short}$ $V_{OD} = 0.8\text{ V}$ | 25 | 17 | - | 37 | μA | |
| Output Current | I_O | $V_{SC} = 1.4\text{ V}$ $V_{OS} = 0.8\text{ V}$ | $I_{S1} = 580\mu\text{A}$ | -30 | -200 | - | μA | |
| | | | $I_{S1} = 530\mu\text{A}$ | 25 | -100 | - | | |
| | | | $I_{S1} = 480\mu\text{A}$ | 85 | -75 | - | | |
| S _C ON Voltage | $V_{SC\ ON}$ | $V^+ = 16\text{ V}$ | 25 | 0.7 | - | 1.4 | V | |
| S _C Input Current | $I_{SC\ ON}$ | $V^+ = 12\text{V}$ | 25 | - | - | 5 | μA | |
| Output "L" Current | I_{OSL} | $V^+ = 12\text{ V}$, $V_{OSL} = 0.2\text{ V}$ | -30 | 200 | - | - | μA | |
| | | | 85 | | | | | |
| Input Clamp Voltage | V_{IC} | $V^+ = 12\text{ V}$, $I_{IC} = 20\text{ mA}$ | -30 85 | 4.3 | - | 6.7 | V | |
| Differential Input Clamp Voltage | V_{IDC} | $I_{IDC} = 100\text{mA}$ | -30 85 | 0.4 | - | 2 | V | |
| Max. Current Voltage | V_{SM} | $I_{SM} = 7\text{ mA}$ | 25 | 20 | - | 28 | V | |
| Supply Current 2 | I_{S2} | $V_{OS} = 0.5\text{ V}$, $V_R - V_I = X$ | -30 85 | - | - | 1200 | μA | |
| Latch Circuit Off Supply Voltage | $V^+ \text{ OFF}$ | | 25 | 0.5 | | | V | |
| Response Time | T_{ON} | $V^+ = 16\text{ V}$, $V_R - V_I = 0.3\text{ V}$ | 25 | 1 | - | 4 | ms | |

Typical Performance Curves

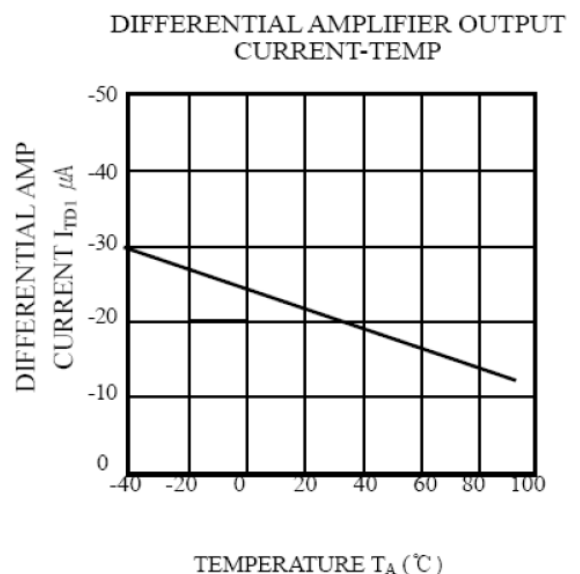
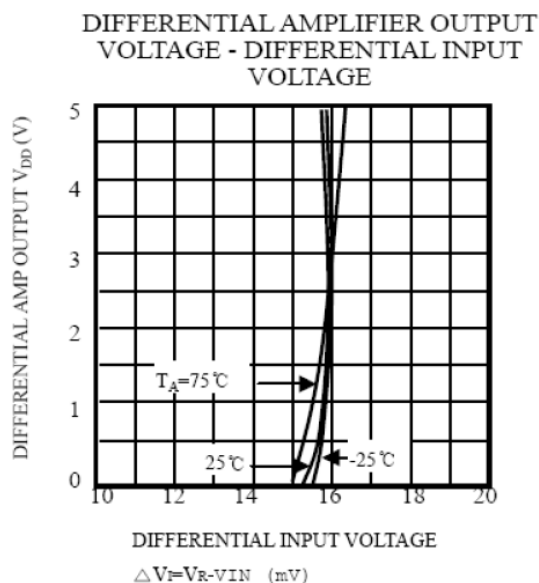
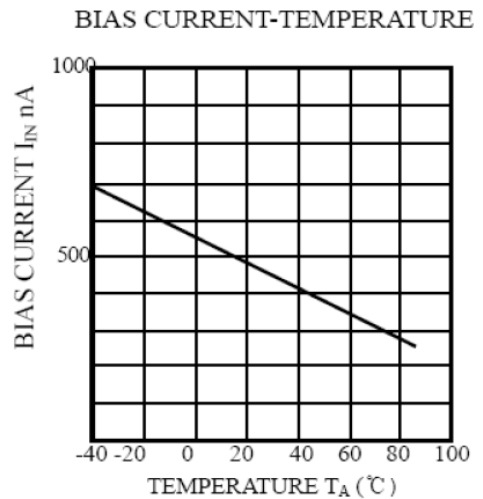
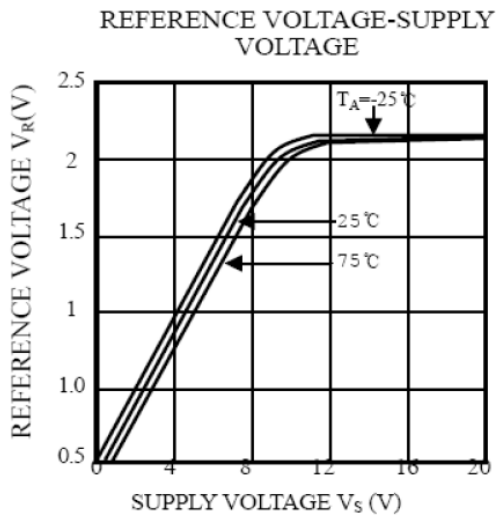
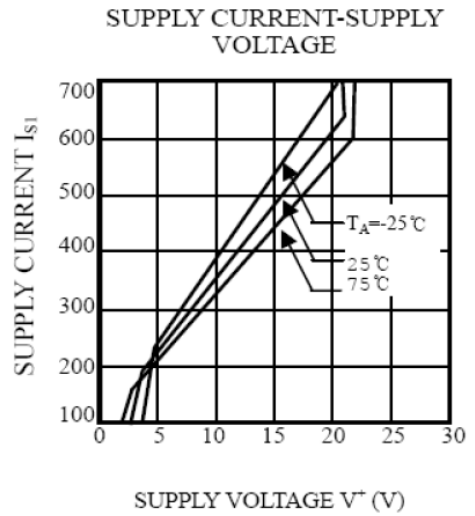
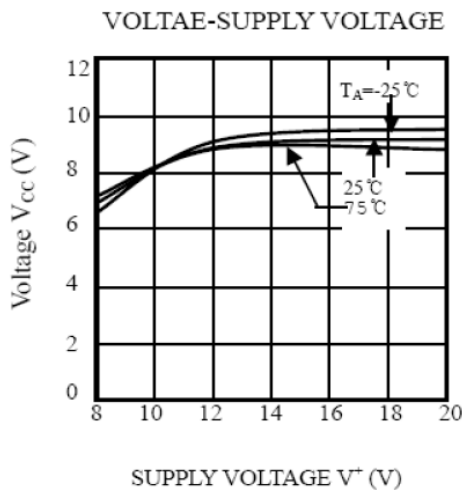

Test Circuit

1.

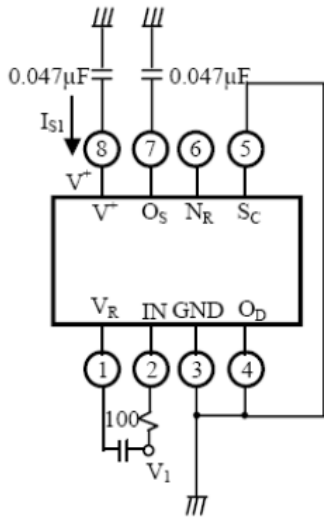

2.

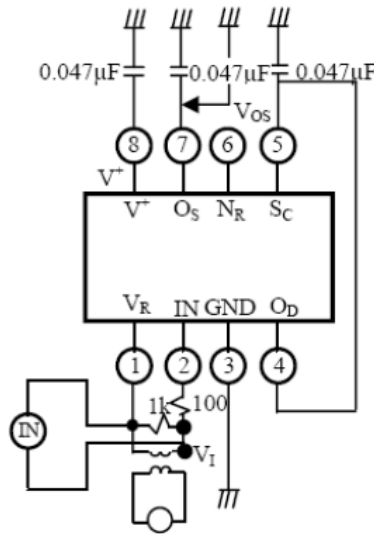

3.

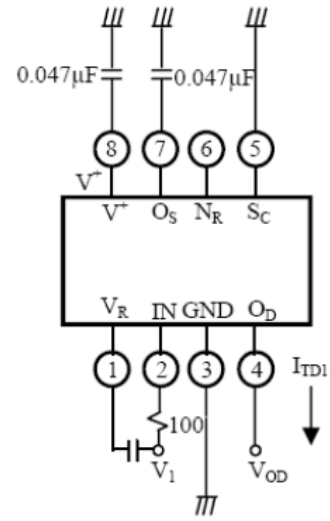

4.

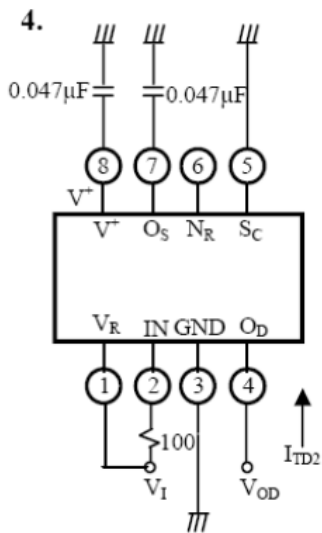

5.

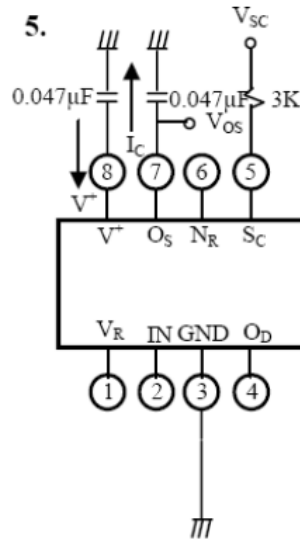

6.

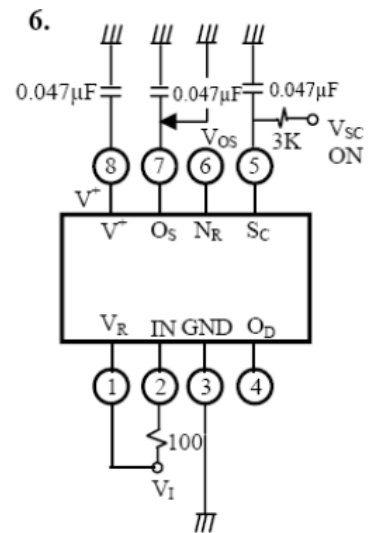

7.

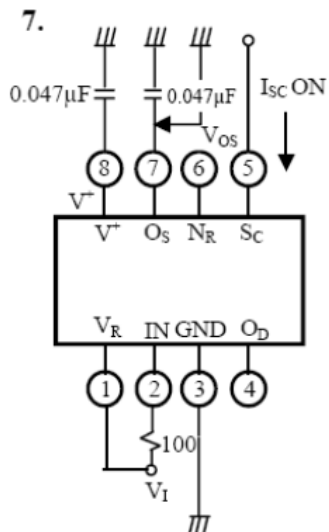

8.

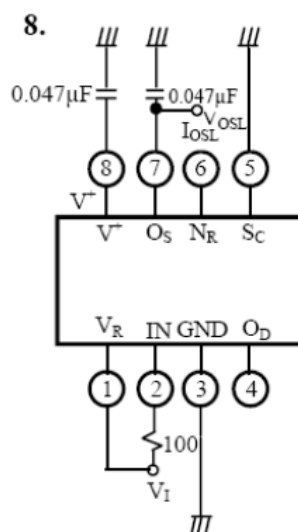

9.

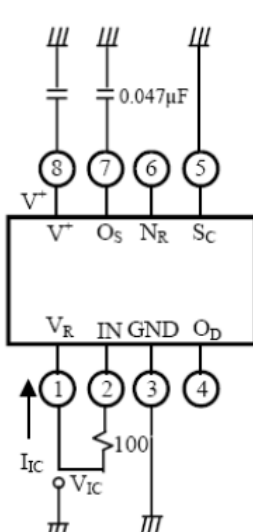

10.

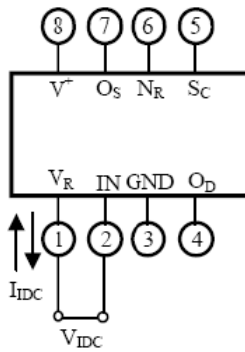

11.

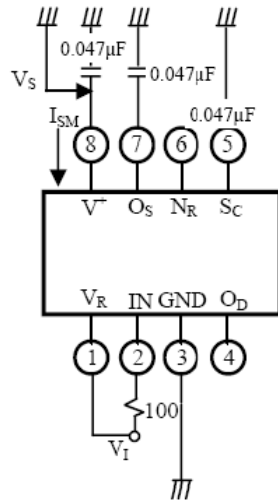

12.

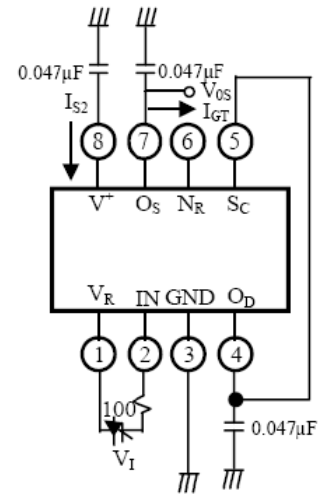

13.

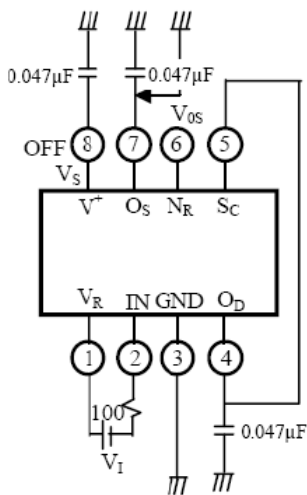

14.

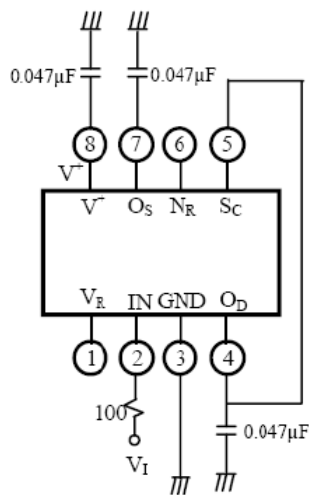

Typical Application

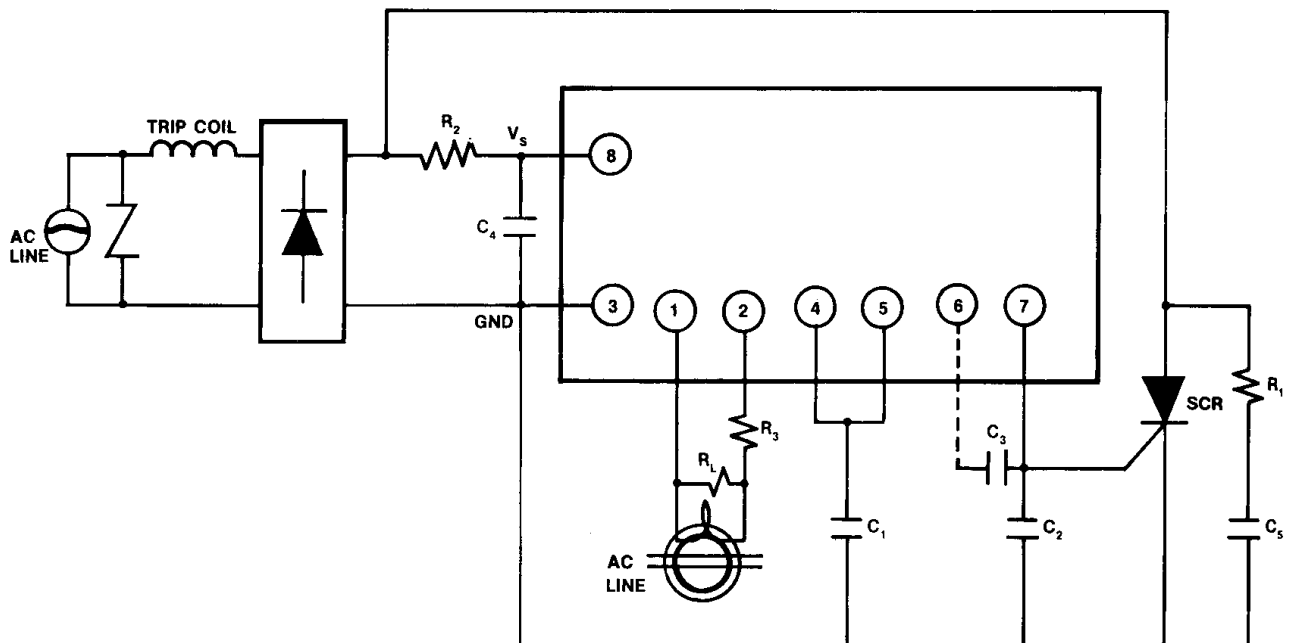

Supply voltage circuit is connected as a previous diagram. Please decide constants R_1 , R_2 , C_4 , and C_5 of a filter in order to keep at least 12V in V_s , when normal supply current flows.

In this case, please connect C_4 (more than $1 \mu F$) and C_2 (less than $1 \mu F$). ZCT and load resistance R_L of ZCT are connected between input pin ① and ②. In this case protective resistance ($R_3=100\Omega$) must be insulated. Sensitivity current is regulated by R_L , and output of amplifier shows in pin ④. External capacitor C_1 between pin ④ and GND is used for noise removal.

When large current is grounded in the primary side (AC line) of ZCT, the wave form in the secondary side of ZCT is distorted and some signals doesn't appear in the output of amplifier. So please connect a varistor or a diode (2pcs.) to ZCT in parallel.

Latch circuit is used to inspect the output level of amplifier and to supply gate current on the external SCR. When input pin becomes more than 1.1V (Typ.) latch circuit operates and supply gate current in the gate of SCR connected to the output pin ⑦.

Pin ⑥ can be used in the open state, but please connect capacitor (about $0.047 \mu F$) between pin ⑥ and ⑦.

Capacitor C_6 between pin ① and GND is used to remove noise and is about $0.047 \mu F$.

N SUFFIX DIP
(MS – 001BA)

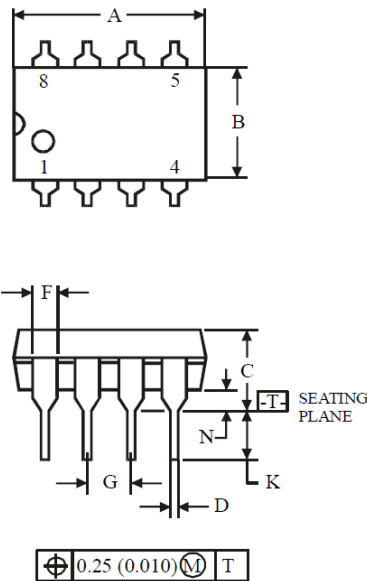
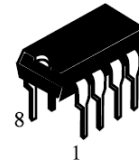

| Symbol | Dimension, mm | |
|--------|---------------|-------|
| | MIN | MAX |
| A | 8.51 | 10.16 |
| B | 6.10 | 7.11 |
| C | | 5.33 |
| D | 0.36 | 0.56 |
| F | 1.14 | 1.78 |
| G | 2.54 | |
| H | 7.62 | |
| J | 0° | 10° |
| K | 2.92 | 3.81 |
| L | 7.62 | 8.26 |
| M | 0.20 | 0.36 |
| N | 0.38 | |

NOTES:

- Dimensions “A”, “B” do not include mold flash or protrusions.
Maximum mold flash or protrusions 0.25 mm (0.010) per side.

D SUFFIX SOP
(MS - 012AA)

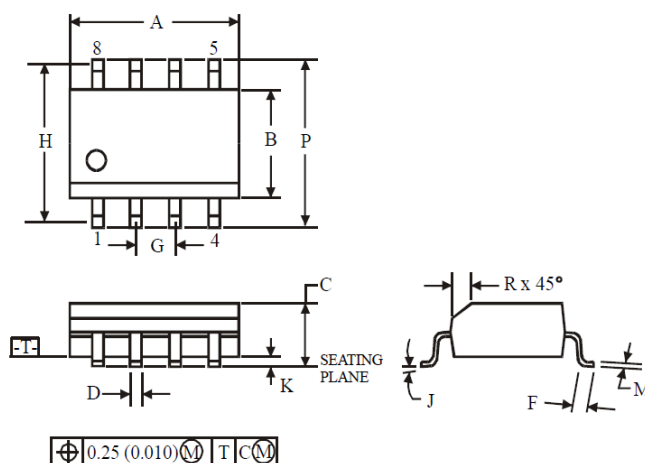

| Symbol | Dimension, mm | |
|--------|---------------|------|
| | MIN | MAX |
| A | 4.80 | 5.00 |
| B | 3.80 | 4.00 |
| C | 1.35 | 1.75 |
| D | 0.33 | 0.51 |
| F | 0.40 | 1.27 |
| G | 1.27 | |
| H | 5.72 | |
| J | 0° | 8° |
| K | 0.10 | 0.25 |
| M | 0.19 | 0.25 |
| P | 5.80 | 6.20 |
| R | 0.25 | 0.50 |

NOTES:

- Dimensions A and B do not include mold flash or protrusion.
- Maximum mold flash or protrusion 0.15 mm (0.006) per side for A; for B - 0.25 mm (0.010) per side.